

SOD-323

250mW SOD-323 Fast Switching Diode

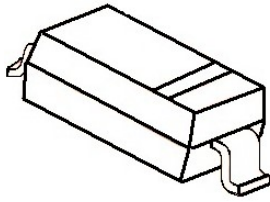

MARKING: A6

**特征 Features**

- 开关速度小于 4.0nS; Fast Switching Device (TRR <4.0 nS)
- 最大功率耗散 250mW; Power Dissipation of 250mW
- 高稳定性和可靠性。High Stability and High Reliability
- 反向漏电流小。Low reverse leakage

**机械数据 Mechanical Data**

- 封装: SOD-323 封装 SOD-323 Small Outline Plastic Package
- 极性: 色环端为负极 Polarity: Color band denotes cathode end
- 安装位置: 任意 Mounting Position: Any

极限值和温度特性(TA = 25°C 除非另有规定)

**Maximum Ratings & Thermal Characteristics** (Ratings at 25°C ambient temperature unless otherwise specified.)

参数 Parameters	符号 Symbol	数值 Value	单位 Unit
反向电压 Reverse Voltage	V <sub>R</sub>	100	V
反向峰值电压 Peak Repetitive Reverse Voltage	V <sub>RRM</sub>	100	V
功率消耗 Power Dissipation	P <sub>d</sub>	250	mW
工作结温 Operating junction temperature	T <sub>j</sub>	150	°C
存储温度 Storage temperature range	T <sub>s</sub>	-55-+150	°C
热阻抗 Thermal Resistance from Junction to Ambient	R <sub>θJA</sub>	500	°C/W
平均整流电流 Average Rectified Current	I <sub>o</sub>	250	mA
正向(不重复)浪涌电流 Non repetitive Peak Forward Surge Current @ tp=8.3ms; TA=25°C	I <sub>FSM</sub>	2.0	A

Valid provided that electrodes are kept at ambient temperature.

**电特性 Electrical Characteristics** (Ratings at 25°C ambient temperature unless otherwise specified).

符号 Symbols	参数 Parameter	测试条件 Test Condition	界限 Limits		单位 Unit
			Min	Max	
V(BR)	反向电压 Reverse Voltage	IR=100uA	100		V
IR	反向漏电流 Reverse Leakage Current	VR=25V	---	30	nA
		VR=75	---	1	uA
VF	正向电压 Forward Voltage	IF=1.0mA	---	0.715	V
		IF=10mA	---	0.855	
		IF=50mA	---	1.00	
		IF=150mA	---	1.25	
TRR	反向恢复时间 Reverse Recovery Time	IF= IR=10mA	---	4	nS
		RL=100Ω			
		IRR=0.1 X IR			
CT	结电容 Capacitance	VR=0V, f=1MHZ	---	1.5	pF

**Typical Characteristics**

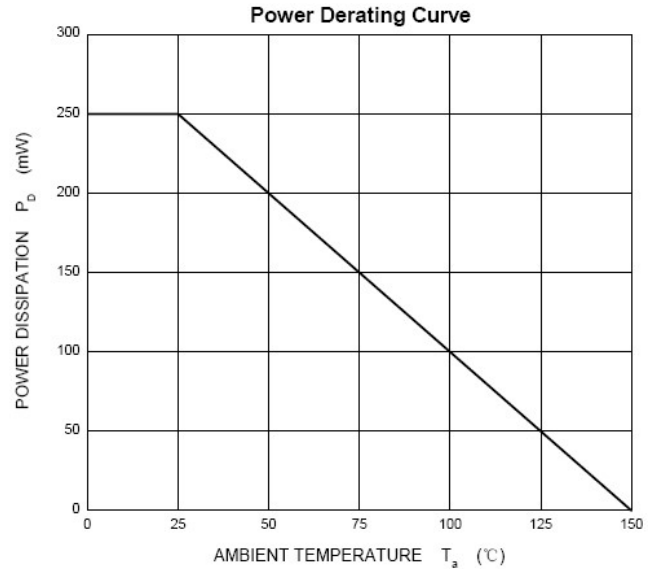
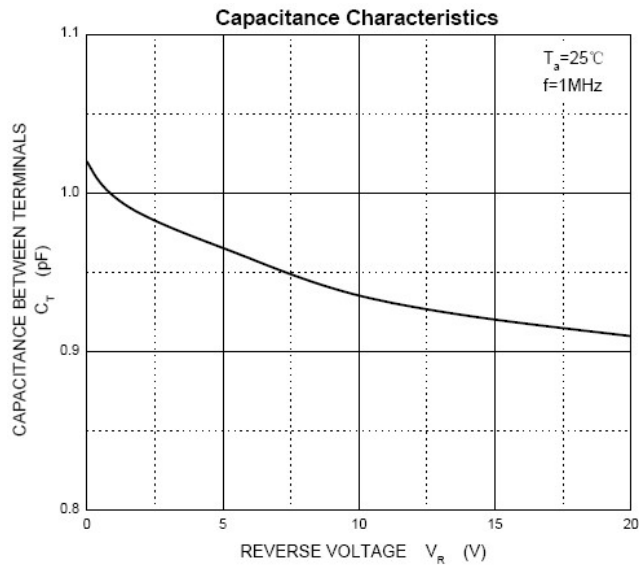
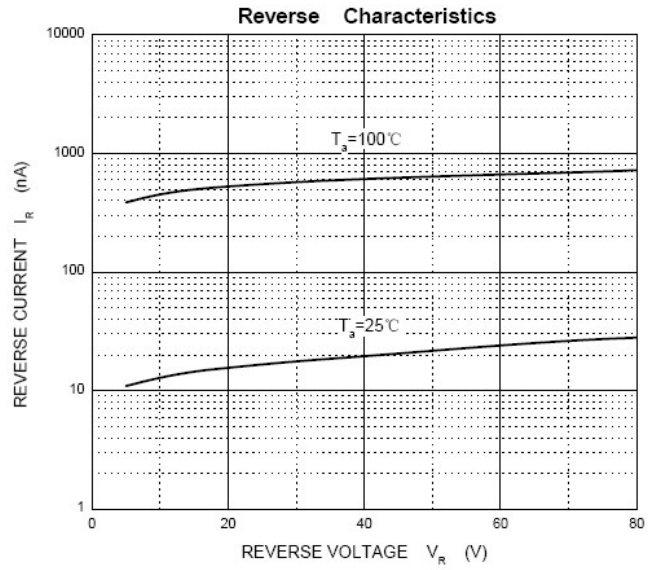
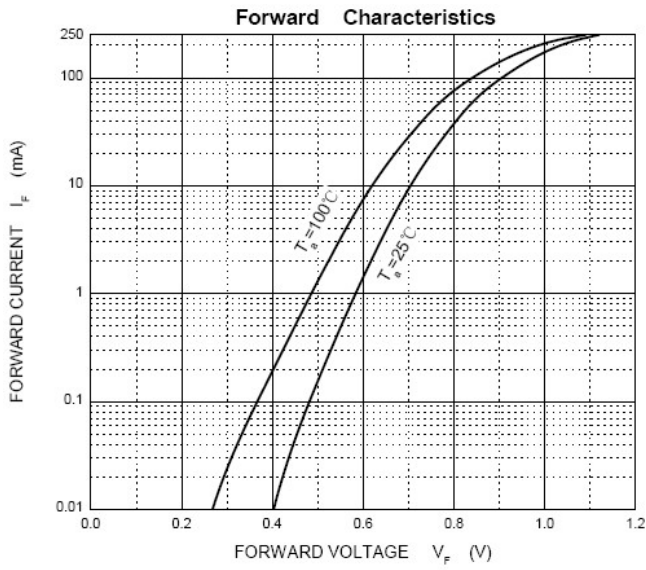

**SOD-323 PACKAGE OUTLINE**

Plastic surface mounted package

**SOD-323**

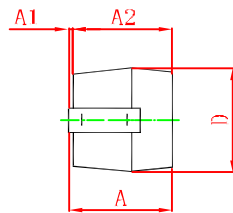
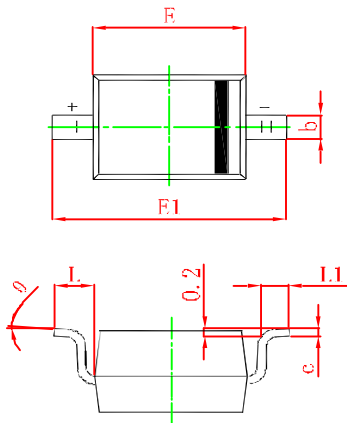

Symbol	Min.(mm)	Max.(mm)
A		1.000
A1	0.000	0.100
A2	0.800	0.900
b	0.250	0.350
c	0.080	0.150
D	1.200	1.400
E	1.600	1.800
E1	2.500	2.700
L	0.475REF	
L1	0.250	0.400
$\theta$	$0^\circ$	$8^\circ$